

MUSIC IN ENGLISH 1st ESO 2018/19

NAME: _____

A les proves de setembre l'alumne lliurarà el treball i farà un examen teòric-pràctic. Els criteris qualificació i els seus percentatges seran:

- Treball (20%).

- Comprensió i expressió

(80%). Dividit en una part teòrica (40%) i una part pràctica (40%)

Estudia aquest treball perquè serà la base de l'examen teòric.

La part pràctica consistirà en interpretar amb la flauta tres cançons, triades per l'alumne de la següent llista: HELP, YELLOW SUBMARINE, TE DEUM, FIESTA PAGANA, TITANIC, SHREK, BAD ROMACE.



NAME: _____

- Write down the Catalan names:

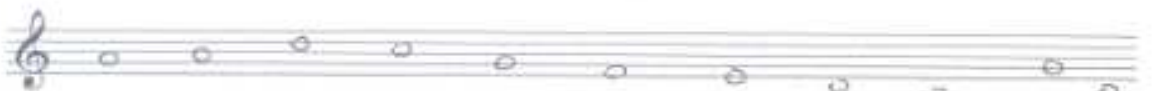

NAME: _____

Write down the bar lines and double barlines:



Draw the notes:

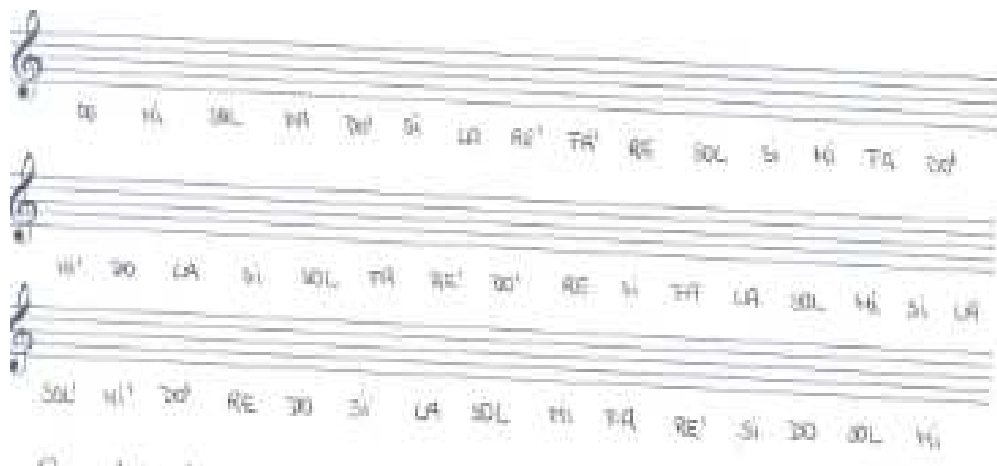

Complete the value chart:

$$\begin{array}{l} 3 \text{ } \downarrow = \square \text{ } \downarrow \quad 1 \text{ } \downarrow = 3 \square \quad 2 \text{ } \circ = \square \text{ } \downarrow \\ 4 \text{ } \downarrow = 2 \square \quad 1 \text{ } \downarrow = \square \text{ } \downarrow \quad 2 \text{ } \downarrow = 8 \square \end{array}$$

NAME: _____

5.- Write down the correct names of the following symbols: 1p



6.- Write the meaning of: 1p

Tongain or articulation:

Syncopation:

7.- Match the definitions and the Italian terms: 1p

Tempo terms	Definitions
Grave	Walking
Adagio	Played very fast
Andante	Slowly and solemnly
Moderato	Lively and briskly
Presto	Medium speed
Viva, vivace	Slow

8.- Complete the fingering chart. Write the English and the Catalan names of the notes:

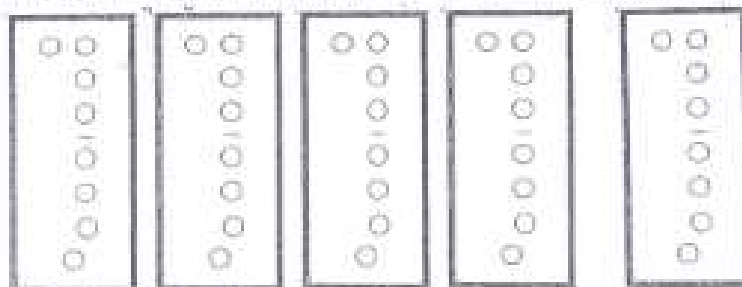

NAME: _____

4.- Wich family are they? _____

Label the different instruments.

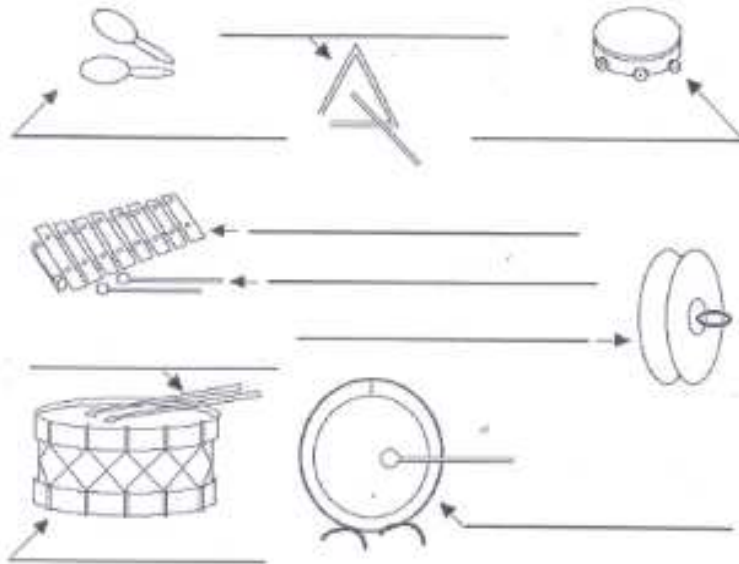

5.- Wich family are they? _____

Label the different instruments.

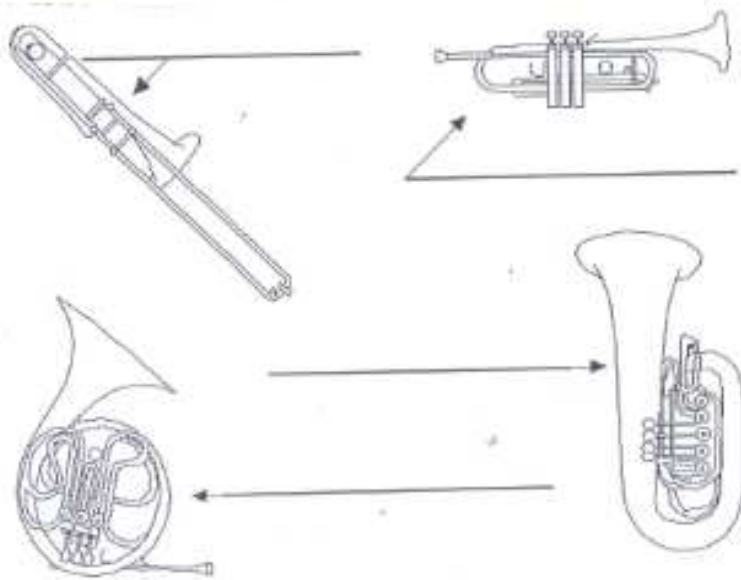

NAME: _____

6.- Wich family are they? _____

Label the different instruments.

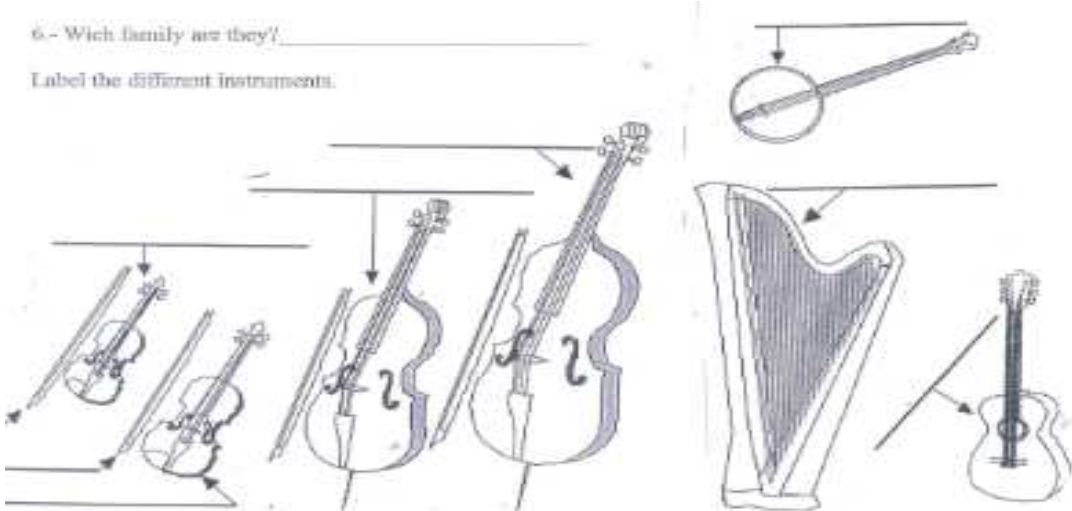

7.- Wich family are they? _____

Label the different instruments.



MUSIC IN ENGLISH 1st ESO 2018/19

NAME: _____

INSTRUMENT RESEARCH:

My favourite instrument is the _____
because I love its _____
It belongs to the _____ family as.....
I think it is useful for playing _____ (kind of music: classical, rock, traditional,
ethnic, pop, any kind ...)
It can make low or high volume sounds...or more suitable for high or low-pitched sounds.
It's made of wood, metal, something else...
It's played by bowing, blowing, scraping, plucking, shaking, or banging or hitting...
it is a tuned or an untuned instrument _____
Its sound is: deep, clear, clean, sharp, metallic, hollow, buzzing, clanking, muffling, amazing
(Look up at the dictionary for the Catalan translation)

4. Complete the fingering chart. Write the English and the Catalan names of the notes.

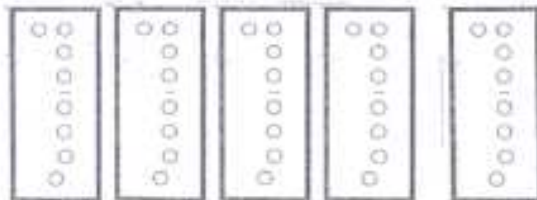

5. Name the different instruments in a Recorder concert:

The smallest one is named _____ the second one _____
the third _____ the fourth _____ the fifth _____
the sixth _____ and the largest one _____

MUSIC IN ENGLISH 1st ESO 2018/19

NAME: _____

1.- The four main voices that make up a choir are:

Woman's voice: high _____
low _____

Man's voice: high _____
low _____

2.- Draw the orchestra scheme, the way they are placed.
Why are they placed in such way?